

***SENSYLINK Microelectronics***

***(CHT8305C)***

***Digital Humidity & Temperature Sensor***

***CHT8305C is a Digital Humidity and Temperature Sensor with  $\pm 3.0\%$  RH Accuracy for humidity and  $\pm 0.5^{\circ}\text{C}$  Accuracy for temperature. It is compatible with I<sup>2</sup>C and 2-wire Interface. It is ideally used in HVAC, environment monitor etc.***

**Table of Contents**

DESCRIPTION .....	4
FEATURES.....	4
APPLICATIONS .....	4
PIN CONFIGURATIONS (TOP VIEW).....	4
TYPICAL APPLICATION .....	4
PIN DESCRIPTION .....	5
FUNCTION BLOCK .....	5
ORDERING INFORMATION.....	6
ABSOLUTE MAXIMUM RATINGS (NOTE3).....	7
RECOMMENDED OPERATING CONDITIONS.....	7
ELECTRICAL CHARACTERISTICS (NOTE4).....	8
<b>1 FUNCTION DESCRIPTIONS .....</b>	<b>11</b>
1.1 REGISTER MAP .....	11
1.1.1 Temperature Measurement Data [Add:0x00].....	11
1.1.2 Relative Humidity Measurement Data [Add:0x01].....	11
1.1.3 Config Register [Add: 0x02].....	12
1.1.4 Alert High Limit Setup [Add: 0x03].....	13
1.1.5 Manufacture ID [Add: 0xFE].....	14
1.1.6 Version ID [0xFF].....	14
1.2 SOFT RESET .....	14
1.3 HEATER .....	15
1.4 DO MEASUREMENT PROCEDURE.....	15
1.4.1 Step 1, Setup The Sensor.....	15
1.4.2 Step 2, Trigger Temperature and Humidity Measurement.....	15
1.4.3 Step 3, Waiting for Conversion Time.....	15
1.4.4 Step 4, Read Out Temperature and Humidity Measurement Data.....	15
1.4.5 Example C51 Code for Reading Out Temperature and Humidity Data.....	15
1.5 DIGITAL INTERFACE.....	17
1.5.1 Slave Address .....	17
1.5.2 Read/Write Operation .....	17
1.6 ALERT OUTPUT .....	19
<b>2 APPLICATION INFORMATION.....</b>	<b>20</b>
2.1 TYPICAL APPLICATION IN HARDWARE .....	20
2.2 PCB LAYOUT.....	20
2.2.1 Device Placement .....	20
2.2.2 Cin, Pull-up Resistor.....	21
2.3 HUMIDITY HYSTERESIS .....	21
2.4 IMPORTANT NOTICES.....	23
2.4.1 Soldering.....	23
2.4.2 Cavity Protection Cover .....	23
PACKAGE OUTLINE DIMENSIONS (DFN3X3-6).....	24
RECOMMEND LAND PATTERN LAYOUT (DFN3X3-6).....	25
PACKING INFORMATION.....	26
REVISION HISTORY.....	27

**Figures and Tables**

Figure 1. Typical Application of CHT8305C .....	4	Table 1. Register Maps Definition .....	11
Figure 2. CHT8305C function block .....	5	Table 2. 16-bit Temperature Data .....	11
Figure 3. Temperature Accuracy .....	9	Table 3. 16-bit humidity Data .....	12
Figure 4. Relative Humidity Accuracy .....	9	Table 4. Status Register Definition .....	12
Figure 5. Shutdown Current .....	9	Table 5. Threshold Bit definition .....	13
Figure 6. Conversion Current .....	9	Table 6. Combination for humidity and temperature high-limit .....	13
Figure 7. I <sup>2</sup> C Timing Diagram .....	10	Table 7. Slave address vs. AD0 pin connection .....	17
Figure 8. I <sup>2</sup> C Write Word (2-Bytes) Timing Diagram .....	18		
Figure 9. I <sup>2</sup> C Read Word (2-Bytes, for temperature or humidity) Timing Diagram .....	18		
Figure 10. ALERT pin logic status .....	19		
Figure 11. Sensor typical application .....	20		
Figure 12. sensor placement example at PCB .....	21		
Figure 13. Sensor PCB layout example .....	21		
Figure 14. Humidity sensor data vs. environment humidity .....	22		
Figure 15. Sensor Humidity Hysteresis vs. environment humidity .....	22		

It's confidential, for 北京联盛德微电子有限公司 On Mar 03, 2022

## Description

CHT8305C is a digital humidity and temperature sensor with  $\pm 3.0\%RH(\text{Max.})$  accuracy for humidity and  $\pm 0.5^\circ\text{C}(\text{Max.})$  accuracy for temperature. Humidity and Temperature data can be read out directly via I<sup>2</sup>C digital interface by MCU, Bluetooth Chip or SOC chip.

CHT8305C supports I<sup>2</sup>C communication with speed up to 400kHz.

Each chip is specially calibrated for temperature and humidity accuracy in factory before shipment to customers. There is no need for re-calibration anymore.

It includes a high precision band-gap circuit, a 14-bit analog to digital converter, a calibration unit with non-volatile memory, and a digital interface block.

It has ALERT logic output pin with open drain structure, which is active low.

The chip supports up to 4 devices in one I<sup>2</sup>C bus by setting different slave address via AD0 pin.

Available Package: DFN3x3-6 package

## Features

- Operation Voltage: 2.5V to 5.5V
- Average Operating Current: 1.5uA (Typ.) at 1.0con/sec, Vcc=3.3V (Both T&RH conversion). 3.0uA (Max.)
- Standby Current: 0.05uA(Typ.), 0.3uA (Max.)
- Temperature Accuracy without calibration: Maximum:  $\pm 0.5^\circ\text{C}$  from  $0^\circ\text{C}$  to  $50^\circ\text{C}$
- Humidity Accuracy without calibration: Maximum:  $\pm 3.0\%RH$  at 50%RH
- 14 bit ADC for Temperature and Humidity
- Compatible with 2-wire and I<sup>2</sup>C interface
- Programmable Alert response of Over Temperature and/or Humidity
- Generate 4 different slave address by setting AD0 pin
- Temperature Range:  $-40^\circ\text{C}$  to  $125^\circ\text{C}$
- Humidity Range: 0%RH to 100%RH
- Protection Cover is available

## Applications

- Smart HVAC System
- Environment Monitor
- Portable/Wearable Weather Monitor

## PIN Configurations (Top View)

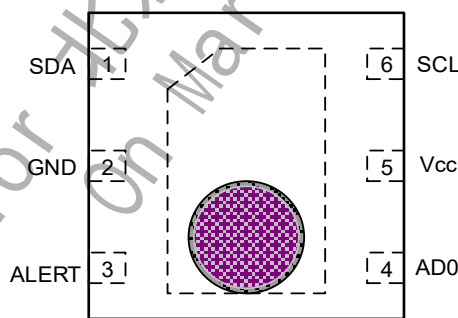

DFN3x3-6(Package Code DN)

## Typical Application

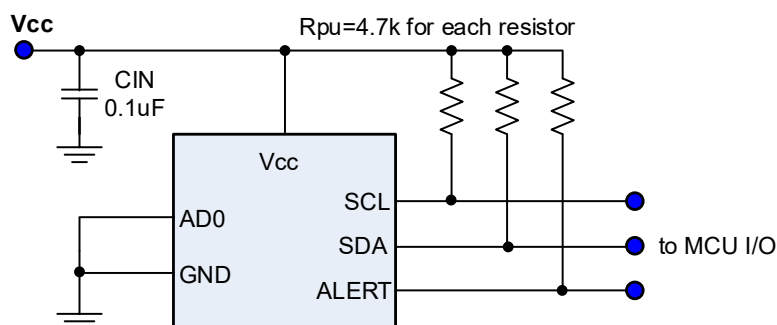

Figure 1. Typical Application of CHT8305C

**Pin Description**

PIN No.	PIN Name	Description
1	SDA	Digital interface data input or output pin, need a pull-up resistor to Vcc.
2	GND	Ground pin.
3	ALERT	To Indicate alert status of over Humidity and/or Temperature limitation programmed by setting H <sub>LIMIT</sub> /T <sub>LIMIT</sub> register. Need a pull-up resistor to Vcc in application. active low with open drain output.
4	AD0	Slave Address selection pins, the chip can be defined total 4 different slave addresses by connecting this pin to GND, Vcc, SCL or SDA pin respectively. If leave this pin open, address is 0x80. See Slave Address for detail.
5	Vcc	Power supply input pin, using 0.1uF low ESR ceramic capacitor to ground
6	SCL	Digital interface clock input pin, need a pull-up resistor to Vcc.

**Function Block**

Figure 2. CHT8305C function block

**Ordering Information**
**CHT8305C X X - X**
**Package Type**  
 DN : DFN3x3-6

**Packing**  
 R: Tape & Reel

**Protection**  
 C : with Cover  
 Blank : without Cover

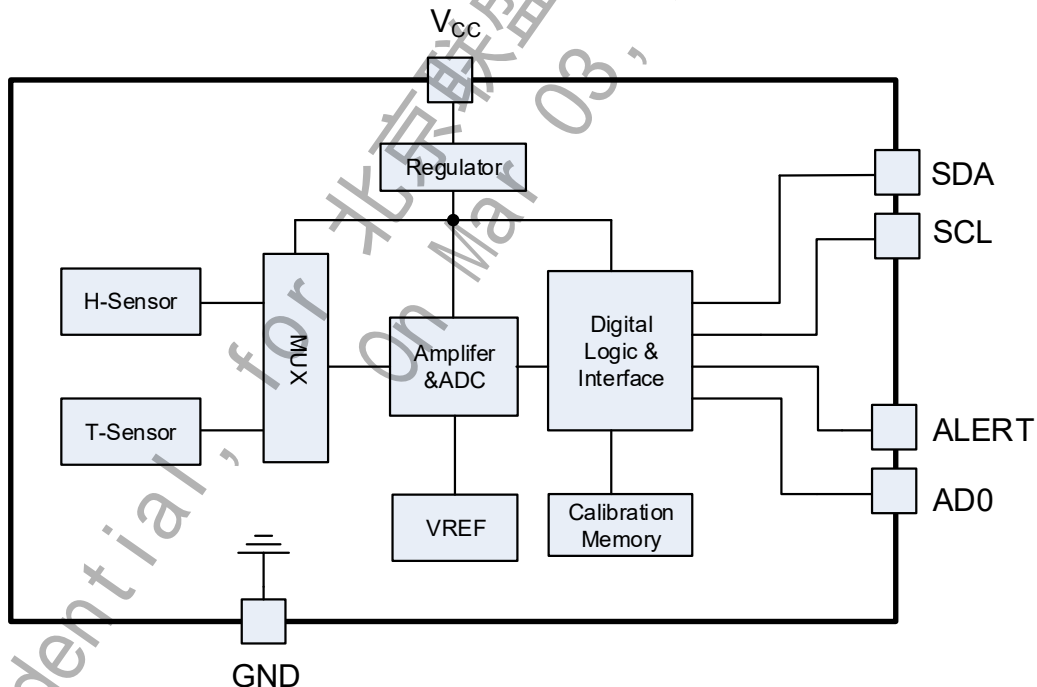
Order PN	Accuracy	Green <sup>1</sup>	Package	Marking ID <sup>2</sup>	Packing	MPQ	Operation Temperature	Protection Cover
CHT8305CDNR	±0.5°C ±3%RH	Halogen free	DFN3x3-6	8305 YWWAXX	Tape & Reel	3,000	-40°C~+125°C	No
CHT8305CDNR-C	±0.5°C ±3%RH	Halogen free	DFN3x3-6	8305 YWWAXX	Tape & Reel	3,000	-40°C~+125°C	Yes

**Notes**

1. Based on ROHS Y2012 spec, Halogen free covers lead free. So most package types Sensylink offers only states halogen free, instead of lead free.

2. Marking ID includes 2 rows of characters. In general, the 1<sup>st</sup> row of characters are part number, and the 2<sup>nd</sup> row of characters are date code plus production information.

**Absolute Maximum Ratings (Note3)**

Parameter	Symbol	Value	Unit
Supply Voltage	$V_{CC}$ to GND	-0.3 to 5.5	V
SDA, SCL, AD0 Voltage	$V_{SDA}/V_{SCL}/V_{AD0}$ to GND	-0.3 to 5.5	V
ALERT Voltage	$V_{ALERT}$ to GND	-0.3 to 5.5	V
Operation junction temperature	$T_J$	-50 to 150	°C
Storage temperature Range	$T_{STG}$	-65 to 150	°C
Lead Temperature (Soldering, 10 Seconds)	$T_{LEAD}$	260	°C
ESD MM	$ESD_{MM}$	400	V
ESD HBM	$ESD_{HBM}$	4000	V
ESD CDM	$ESD_{CDM}$	1000	V

**Note3**

1. Stresses greater than those listed under "Absolute Maximum Ratings" may cause permanent damage to the device. These are stress ratings only. Functional operation of the device at the "Absolute Maximum Ratings" conditions or any other conditions beyond those indicated under "Recommended Operating Conditions" is not recommended. Exposure to "Absolute Maximum Ratings" for extended periods may affect device reliability.
2. Using 2oz dual layer (Top, Bottom) FR4 PCB with 2.5x1.4 mm<sup>2</sup> cooper as thermal PAD

**Recommended Operating Conditions**

Parameter	Symbol	Value	Unit
Supply Voltage	$V_{CC}$	2.5 ~ 5.5	V
Ambient Operation Temperature Range	$T_{AT}$	-40~+125	°C
Ambient Operation Temperature Range for Humidity	$T_{ATH}$	0~ +85	°C
Ambient Operation Humidity Range	$T_{AH}$	0~100	%RH

**Electrical Characteristics (Note4)**

 Test Conditions:  $C_{IN} = 0.1\mu F$ ,  $V_{CC} = 3.3V$ ,  $T_A = 25^\circ C$  unless otherwise specified.

Parameter	Symbol	Test Conditions	Min	Typ	Max	Unit
Supply Voltage	$V_{CC}$		2.5		5.5	V
Shutdown Current	$I_{SHUTDOWN}$	Idle, no iteration on SDA/SCL		0.05	0.3	$\mu A$
Open Drain Output Voltage	$V_{OL}$	ALERT pin, sink 5mA	0		0.4	V
Open Drain Leakage	$I_{ODL}$	ALERT pin	-1.0		1.0	$\mu A$
Heater Current	$I_{HEATER}$	Peak Current during Heater Enable		7.0		mA
<b>Temperature Sensor</b>						
Temperature Accuracy	$T_{AC}$	$T_A = 0$ to $50^\circ C$	-0.5	$\pm 0.3$	0.5	$^\circ C$
		$T_A = -20$ to $85^\circ C$	-1.0	$\pm 0.5$	1.0	$^\circ C$
		$T_A = -40$ to $125^\circ C$	-2.0	$\pm 1.0$	2.0	$^\circ C$
Temperature Resolution		14-bit	0.02		$^\circ C$	
Conversion time	$t_{CON}$	14-bit for Temperature		5.0		ms
Conversion Current	$I_{CON}$	14-bit		150		$\mu A$
<b>Humidity Sensor</b>						
Humidity Accuracy	$H_{AC}$	$H_A = 50\%RH$		$\pm 2$	$\pm 3$	%RH
		$H_A = 20\%RH$ to $80\%RH$		$\pm 3$	$\pm 5$	%RH
		$H_A = 5\%RH$ to $95\%RH$		$\pm 5$		%RH
Humidity Resolution		14-bit	0.02		%RH	
Humidity Hysteresis	$H_{HYS}$			$\pm 1.0$		%RH
Humidity Response time	$t_{63\%}$			8		s
Conversion time	$t_{CON}$	14-bit for Temperature		5.0		ms
Conversion Current	$I_{CON}$	14-bit		175		$\mu A$
<b>Digital Interface</b>						
Logic Input Capacitance	$C_{IL}$	SDA, SCL pin		3.0		pF
Logic Input High Voltage	$V_{IH}$	SDA, SCL pin	$0.7 \cdot V_{CC}$		$V_{CC} + 0.3$	V
Logic Input Low Voltage	$V_{IL}$	SDA, SCL pin	-0.3		$0.3 \cdot V_{CC}$	V
Logic Input Current	$I_{INL}$	SDA, SCL pin	-1.0		1.0	$\mu A$
Logic Output Sink Current	$I_{OLS}$	SDA, SCL pin, forced 0.2V		4.0		mA
SCL frequency	$f_{CLK}$	Fast Speed Mode	1		400	kHz
Clock low period time	$t_{LOW}$	Fast Speed Mode	1300			ns
Clock high period time	$t_{HIGH}$	Fast Speed Mode	600			ns
Bus free time	$t_{BUF}$	Between Stop and Start condition	1200			ns
Hold time after Start condition	$t_{HD:STA}$		600			ns
Repeated Start condition setup time	$t_{SU:STA}$		600			ns
Stop condition setup time	$t_{SU:STO}$		600			ns
Data Hold time	$t_{HD:DAT}$		100			ns
Data Setup time	$t_{SU:DAT}$		100			ns
Clock/Data fall time	$t_F$				300	ns
Clock/Data rise time	$t_{SR}$				1000	ns

**Note 4:**

- All devices are 100% production tested at  $T_A = +25^\circ C$ ; All specifications over the automotive temperature range is guaranteed by design, not production tested.
- Time for the RH output to change by 63% of the total RH change after a step change in environmental humidity.
- For humidity accuracy, it excludes hysteresis, high temperature bake, hydration drift, long-term drift.



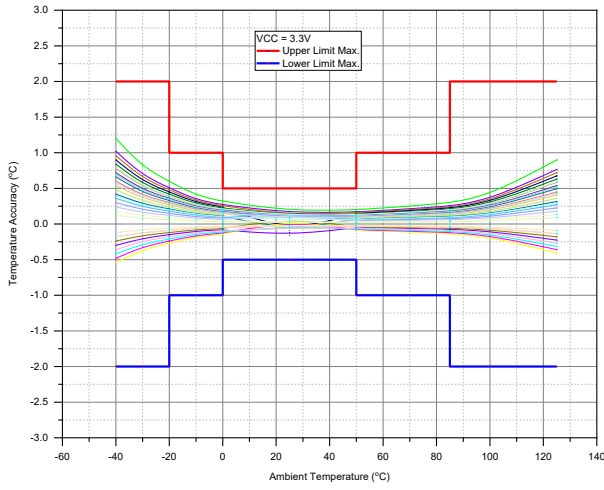

Figure 3. Temperature Accuracy

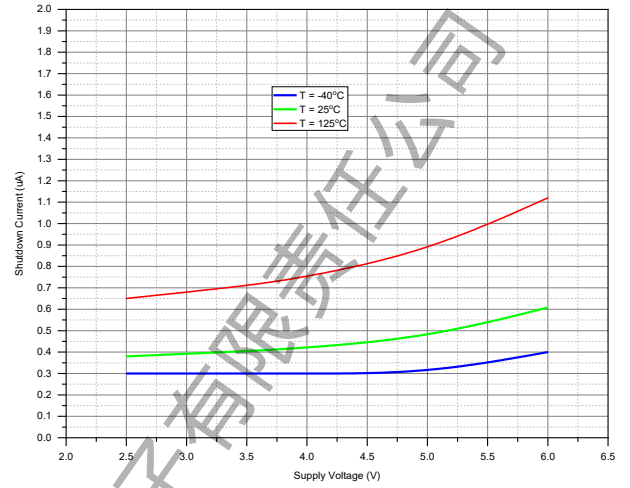

Figure 5. Shutdown Current

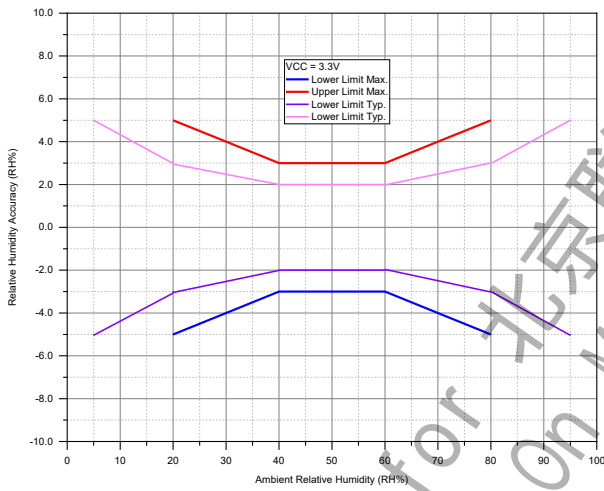

Figure 4. Relative Humidity Accuracy

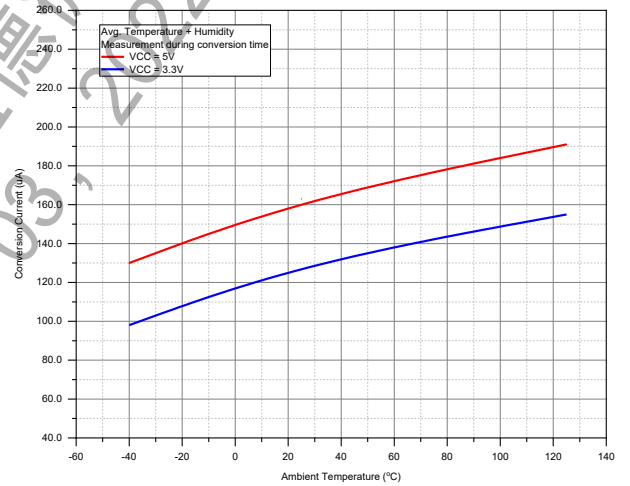
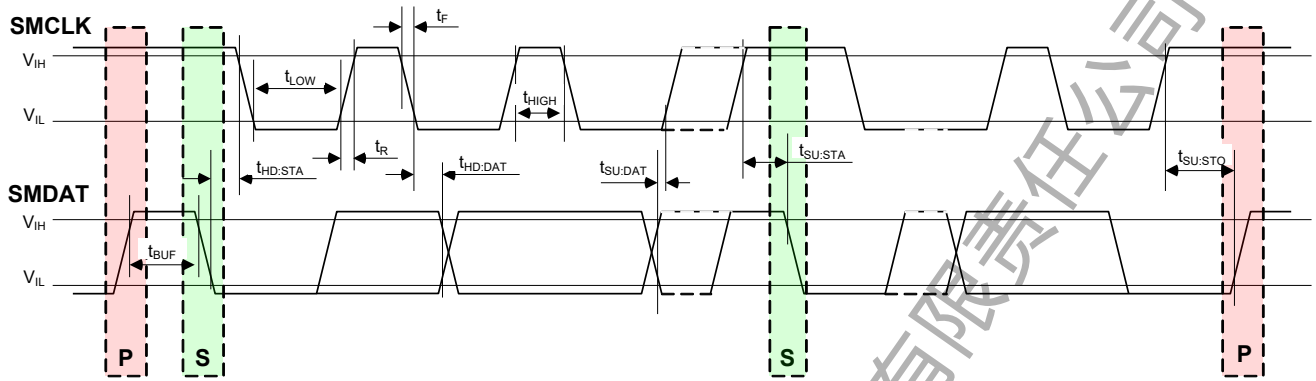

Figure 6. Conversion Current

 Figure 7. I<sup>2</sup>C Timing Diagram

## 1 Function Descriptions

The chip can sense both temperature and humidity. It has integrated temperature and humidity sensor transducers, an analog-to-digital converter, signal processing, calibration, polynomial fit correction, and an I<sup>2</sup>C interface in a single chip. The chip is individually calibrated for both temperature and humidity before shipment using on-chip non-volatile memory. It is permitted to connect 4 devices at the same I<sup>2</sup>C bus by setting AD0 PIN. The SDA and SCL pins integrate spike-suppression filters and Schmitt triggers to minimize the effects of input spikes and bus noise. After power-up, the sensor enters standby mode until a communication or humidity and/or temperature measurement is performed. All output data bytes are transmitted MSB first. Also the chip supports programmable high-limit of temperature and humidity settings. If the measured temperature and/or humidity exceeds the high-limit threshold (T<sub>TH</sub>, H<sub>TH</sub>), ALERT pin will be asserted low. Once the measured temperature goes below the high-limit threshold, ALERT pin will be released.

### 1.1 Register Map

The sensor has 6 registers that user can access. The detail information is shown as below.

Table 1. Register Maps Definition

Register Address	Name	Default	Attribution*	Description
0x00	Temperature	0x0000	R/O	Temperature measurement data.
0x01	Humidity	0x0000	R/O	Relative humidity measurement data.
0x02	Config	0x1000	R/W	Sensor for configuration and status.
0x03	Alert Setup	0xCD36	R/W	High-limit setup for Temperature and Humidity
0xFE	Manufacture ID	0x5959	R/O	Manufacture ID
0xFF	Identification ID	0x8XXX	R/O	Internal identification code

\*Note: R/O, means ready only; R/W means readable/writable.

#### 1.1.1 Temperature Measurement Data [Add:0x00]

The temperature measurement data is stored in Read Only temperature register. The temperature register is in 16-bit binary format with 2-Bytes. Actually only 14 bits (bit15 to bit2) are valid, bit1 and bit 0 are always '0'. This 2-Bytes Temperature data must be read at the same time in each reading cycle, 1<sup>st</sup>-Byte is MSB followed by 2<sup>nd</sup>-Byte, the LSB. The relationship between temperature data in Celsius degree and binary data is shown as below formula (1).

Table 2. 16-bit Temperature Data

Bit	Attribution	Temperature Data
Bit15 to bit2	Read only	Valid data, 0 or 1
Bit1 to bit0	Read only	Always 0

$$\text{Temperature}(^{\circ}\text{C}) = 165 * \frac{\text{Temperature}[\text{bit15:0}]}{2^{16}-1} - 40 \dots (1)$$

#### 1.1.2 Relative Humidity Measurement Data [Add:0x01]

The relative humidity measurement data is stored in Read Only humidity register. The humidity register is in 16-bit binary format with 2-Bytes. Actually only 14 bits (bit15 to bit2) are valid, bit1 and bit 0 are always '0'. This 2-Bytes data must be read at the same time in each reading cycle, 1<sup>st</sup>-Byte is MSB followed by 2<sup>nd</sup>-Byte, the LSB. The relationship between humidity data in %RH and binary data is shown as below formula.

Table 3. 16-bit humidity Data

Humidity Data	Attribution	Humidity Data
Bit15 to bit2	Read only	Valid data, 0 or 1
Bit1 to bit0	Read only	Always 0

$$\text{Relative Humidity}(\%RH) = 100\% * \frac{\text{Humidity}[\text{bit15:0}]}{2^{16}-1} \dots (2)$$

**Notice :** Reading the humidity must read the temperature first, therefore, the user can read four bytes continuously by reading the 00 register, and read out the temperature and humidity value at the same time

### 1.1.3 Config Register [Add: 0x02]

The chip has a 16-bit (2-Bytes) configuration register, which is readable/writable attribution for user. User can change related bit to setup features, like Alert trigger, clock stretching, heater ON/OFF etc. Also user can read out register data to check the chip working status. And the register will reset to default data after power-up. 16 bits definition is shown as below table.

Table 4. Status Register Definition

BIT	15	14	13	12	11	10	9	8
definition	SRST	CLKSTR	Heater	Reserved	Vccs	T_RES	H_RES	
	0	0	0	1	0	0	00	
BIT	7	6	5	4	3	2	1	0
definition	ALTM		APS	HALT	TALT	Reserved	Reserved	
default	00		0	0	0	0	00	

[bit2 is reserved for internal test with R/W attribution, DO NOT write '1'b into this bit during application.](#)

#### SRST, Software Reset bit

'1' -- means soft reset.

'0' -- means normal operation.

default: 0

#### Heater

'1' -- means Heater ON.

'0' -- means Heater OFF.

default: 0

#### T\_RES, Temperature resolution bit

'1' -- means 11-bit.

'0' -- means 14-bit.

default: 0

#### ALTM, Alert trigger mode selection bit

'00' -- either T or RH happens, ALT pin is active.

'01' -- only T happens, ALT pin is active.

'10' -- only RH happens, ALT pin is active.

'11' -- Both T&RH happens, ALT pin is active.

default: 00

#### CLKSTR, clock stretching

'1' -- means clock stretching enable.

'0' -- means clock stretching disable.

default: 0

#### Vccs, Supply Voltage Status bit

'0' -- means >2.8V.

'1' -- means <2.8V.

default: 0

#### H\_RES, Humidity resolution bit

'10' -- means 8-bit.

'01' -- means 11-bit.

'00' -- means 14-bit.

default: 00

#### APS, Alert Pending Status bit

'1' -- means at least one pending alert.

'0' -- means no pending alert.

default: 0

**HALT, Humidity Alert Status bit**

'1' -- means alter.

'0' -- means no alter.

default: 0

**TALT, Temperature Alert Status bit**

'1' -- means alter.

'0' -- means no alter.

default: 0

**1.1.4 Alert High Limit Setup [Add: 0x03]**

The chip features high-limit of temperature and humidity at ALERT pin. When temperature and/or humidity of measured achieves or exceeds threshold temperature and humidity setup by user, ALERT pin will be active. Once both temperature and humidity measured fall below threshold value, ALERT pin will be released from active status. ALERT pin is open drain output with active low. It is necessary to use external pull-up resistor of 4.7k to 10k in application. The default status of ALERT pin is NOT active after power on or soft reset the chip. ALERT pin trigger happens after each measurement cycle. In each measurement cycle, the chip will compare data of temperature and humidity register to that of threshold register. Comparing result will be performed at both ALERT pin and related bit of configuration register (bit4, bit3).

For threshold temperature and humidity data, the format is shown as below.

Table 5. Threshold Bit definition

BIT	15	14	13	12	11	10	9	8	7	6	5	4	3	2	1	0
Default:0xCD36 RH=80%,T=60°C	1	1	0	0	1	1	0	1	0	0	1	1	0	1	1	0
	Humidity							Temperature								

The 1st 7bits are used for humidity threshold and the last 9bits are used for temperature threshold data.

The relationship between binary data and threshold data is shown as below sample.

Step 1, using zero '0' as LSB to complete 16 bits format data.

for Humidity, **1100 1100 0000 0000**

for Temperature, **1001 1011 0000 0000**

Step 2, using above formula to calculate temperature and humidity respectively.

$$\text{Relative Humidity}(\%RH) = 100\% * \frac{\text{Humidity}[\text{bit15:0}]}{2^{16} - 1} = 100\% * \frac{52224}{65535} = 79.7\%RH \approx 80\%RH$$

$$\text{Temperature}(\text{°C}) = 165 * \frac{\text{Temperature}[\text{bit15:0}]}{2^{16} - 1} - 40 = 165 * \frac{39680}{65535} - 40 = 59.9\text{°C} \approx 60\text{°C}$$

Conversely, it is easy to convert threshold data into binary format for 7-bits humidity and 9-bits temperature.

For example, set threshold for humidity as 90%RH, 80°C for temperature.

Step 1, convert threshold data into binary according to above formula.

Humidity, **1110 0110 0110 0101**, only keep the fist 7-bits[1110 011], remove all rest bits.

Temperature, **1011 1010 0110 1101**, only keep the fist 9-bits[1011 1010 0], remove all rest bits.

Step 2, then combine Humidity and Temperature binary data to compose full 16 bit format

Table 6. Combination for humidity and temperature high-limit

BIT	15	14	13	12	11	10	9	8	7	6	5	4	3	2	1	0
	1	1	1	0	0	1	1	1	0	1	1	1	0	1	0	0
	Humidity							Temperature								

Based on above example, the threshold resolution for humidity is  $512/65535 = 0.78\%RH$ , for temperature is  $128/65535 * 165 = 0.32^{\circ}C$ . The binary threshold data can be read & write by reading and writing command shown as below.

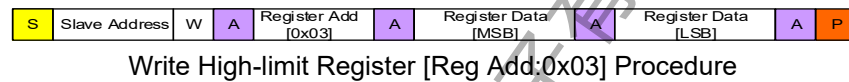
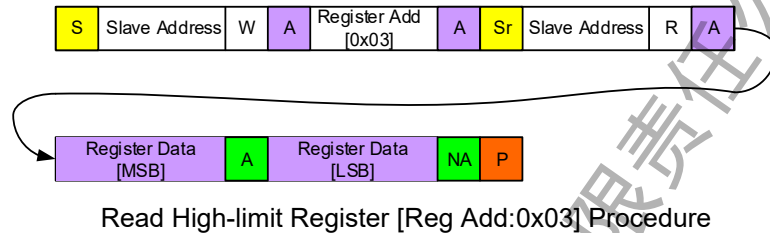

#### 1.1.5 Manufacture ID [Add: 0xFE]

Manufacture ID is the ready only register, for this sensor, the data is 0x5959.

#### 1.1.6 Version ID [0xFF]

Version ID is another ready only register, which stands for internal identification code.

### 1.2 Soft Reset

Generally the chip will reset itself internally during power up every time. Also the chip supports reset without power off by using soft reset command. When bit15 of config register is set to '1', the sensor will perform reset. After finishing reset, all registers will become the default data and the chip will reload calibration data from the memory. And bit15 will be read as '0'.

### 1.3 Heater

The chip has integrated a resistive heater device that could be used to raise the temperature of the sensor. The heater can be switched on and off by setting bit13 as '1' or '0' of config register. After a reset the heater is disabled (as default). This can be used to drive off condensation, or to implement dew-point measurement. Turning on the heater will reduce the tendency of the humidity sensor to accumulate an offset especially at high humidity conditions. The heater current is slightly changed by Vcc voltage.

### 1.4 Do Measurement Procedure

The sensor can be easily used to read out temperature and humidity data by following steps below:

#### 1.4.1 Step 1, Setup The Sensor

It is necessary to setup the sensor by writing proper data into config register [Reg Add:0x02], like temperature resolution (bit10, T\_RES) and humidity resolution (bit9, bit8, RH\_RES). Of course it is ok to use the default setup, just ignore this step.

#### 1.4.2 Step 2, Trigger Temperature and Humidity Measurement

Trigger temperature measurement by writing register address, 0x00 into the sensor via I<sup>2</sup>C bus.

#### 1.4.3 Step 3, Waiting for Conversion Time

The typical conversion time of temperature and humidity is 11ms with 14-bit, during the conversion, the sensor will NOT ACK reading action at I<sup>2</sup>C bus until one-time conversion is finished. Also the clock will be stretching if user set CLKSTR '1' (bit12 of config).

#### 1.4.4 Step 4, Read Out Temperature and Humidity Measurement Data

Once conversion is finished, temperature and humidity raw data can be obtained by reading register 0x00, respectively via I<sup>2</sup>C bus.

#### 1.4.5 Example C51 Code for Reading Out Temperature and Humidity Data

Here is the C51 code as example, to show the method of reading out temperature and humidity register data.

```
bit Read_CHT8305C_temp_humi(void)
{
    unsigned char CHT8305C_temp_h, CHT8305C_temp_l;
    unsigned char CHT8305C_humi_h, CHT8305C_humi_l;
    unsigned int cht8305_temp, cht8305_humi;
    float CHT8305C_temp, CHT8305C_humi;
    iic_start();
    writex(i2c_dev_adr); //if ADO pin connected Gnd or floating, i2c_dev_adr is 0x80
    if(check_ACK())
        return 0;
    writex(0x00);
    check_ACK();
}
```

```

delay_tm(20); //delay time must greater than 20ms
iic_start();
writex(i2c_dev_adr|0x01);
check_ACK();
CHT8305C_temp_h=readx();
set_ACK();
CHT8305C_temp_l=readx();
set_ACK();
CHT8305C_humi_h=readx();
set_ACK();
CHT8305C_humi_l=readx();
set_NAK();
iic_stop();
cht8305_temp=(CHT8305C_temp_h<<8) + CHT8305C_temp_l;
cht8305_humi=(CHT8305C_humi_h<<8) + CHT8305C_humi_l;
CHT8305C_temp=(165*cht8305_temp)/65535.0-40.0;
CHT8305C_humi=cht8305_humi/65535.0;
printf("current temperature is %.2f\n",CHT8305C_temp);
printf("current humidity is %.2f\n",CHT8305C_humi);
return 1;
}

```

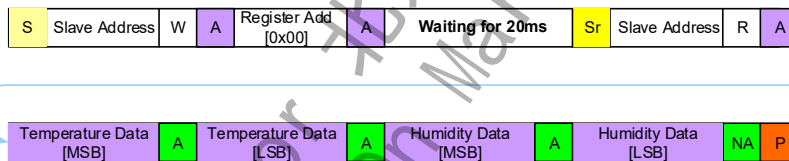



## 1.5 Digital Interface

### 1.5.1 Slave Address

The chip is compatible with industry standard I<sup>2</sup>C protocol as slave device communication with host via SDA and SCL pin. Both SDA and SCL pin are open drain structure. So it is necessary to use 2 pull-up resistors of 4.7k to 10k. The communication speed supports up to 400 kHz. The I<sup>2</sup>C slave address of this device can be configured with 4 different addresses by setting AD0 pin. See below table for details. This permits connecting total of 4 devices in one same bus. Keeping AD0 pin float is the same as connecting AD0 pin to GND.

Table 7. Slave address vs. AD0 pin connection

No.	AD0	Slave Address in Bin
1	GND	7'b1000000
2	Vcc	7'b1000100
3	SDA	7'b1001000
4	SCL	7'b1001100

### 1.5.2 Read/Write Operation

The chip supports basic standard protocols of Read/Write operation, shown as below figures. For CHT8305C, all register data is 16bit, 2-Bytes format.

Read Operation: Host generates start 'S' signal at first, then sends out slave address (R/W bit=0) of the chip set by user; the chip will ACK the slave address by pulling SDA low, then the host sends out register address, and the chip will acknowledge. Then the host will generate re-start 'Sr', then send out slave address again (R/W bit=1); the chip will ACK again with the output 16-bit (2-Bytes) data with MSB first, then LSB; the host has to ACK the MSB byte. Then the host sends out ACK or NACK with stop 'P' at last.

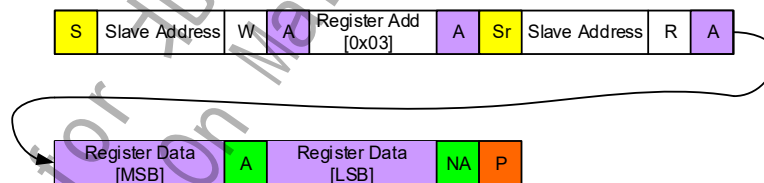

Read (2-Bytes) Operation Figures

Write Operation: host generates start 'S' signal at first, then sends out slave address (R/W bit=0) of the chip set by user; the chip will acknowledge the slave address by pulling SDA low, then the host sends out register address. The chip will acknowledge. The host will send out 16-bit (2-Bytes) data to be written with MSB first, then LSB; the sensor will ACK byte by byte. Then host sends out stop 'P' at last.

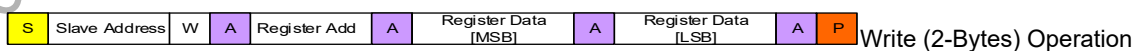

Write (2-Bytes) Operation Figures

\*Note: the chip will NOT ACK the slave address byte until conversion is finished if read 0x00 or 0x01 register.

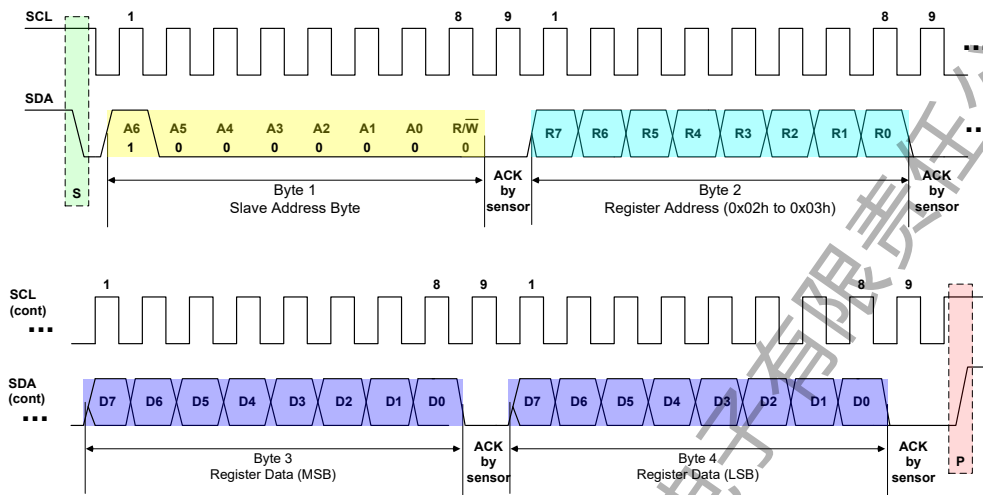
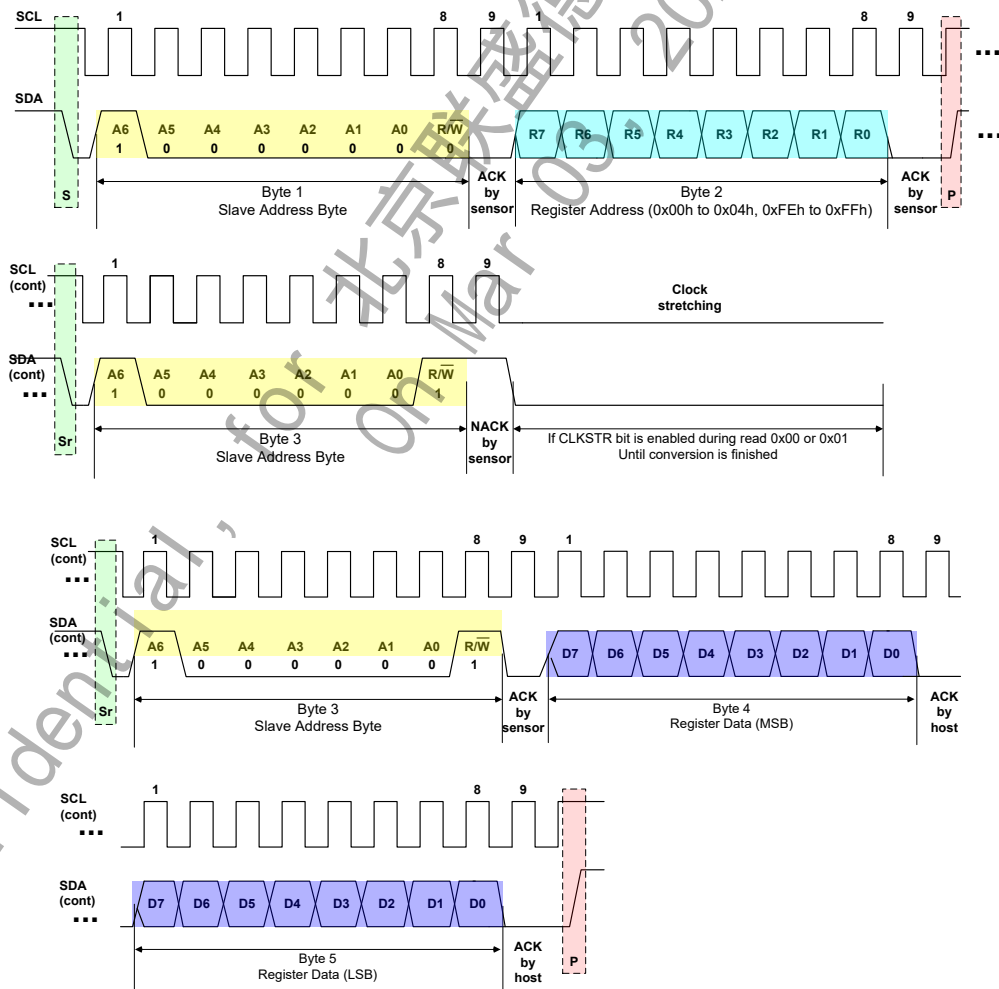
**Figure 8. I<sup>2</sup>C Write Word (2-Bytes) Timing Diagram**

**Figure 9. I<sup>2</sup>C Read Word (2-Bytes, for temperature or humidity) Timing Diagram**

**1.6 ALERT Output**

ALERT pin is open drain output with active low. And it is triggered when the measured temperature and/or humidity equals or exceeds the high-limit threshold temperature and humidity setup by user. The ALERT pin can be used to connect to the interrupt pin of a microcontroller. It should be connected to a pull-up resistor in application shown in Figure 1. The logic status of ALERT pin is shown as in Figure 10.

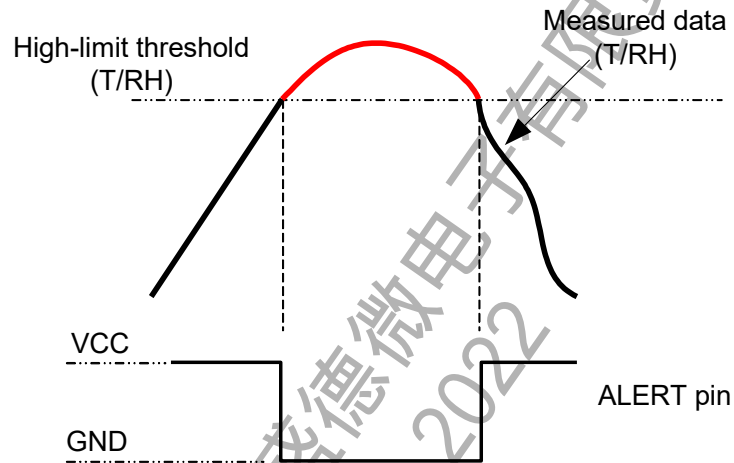

Figure 10. ALERT pin logic status

## 2 Application Information

In order to correctly and accurately sense the ambient temperature and humidity, the chip should be kept away from heat sources, RF module and big size components on the PCB. Also to minimize the error caused by self-heating it is recommended to measure at a maximum sample rate of 1mps (1 time measurement per second) (H + T). In general application, 0.5mps or even lower monitoring frequency of humidity and temperature is good enough.

### 2.1 Typical Application in Hardware

For the sensor, voltage range ( $V_{cc}$ ) can be applied by 2.5V to 5.5V. The formula is shown as below. It is necessary to use 4.7k pull-up resistors for I<sup>2</sup>C Bus (SDA, SCL pin). If I<sup>2</sup>C bus is available in system, which means pull-up resistors have been placed, just connect SDA, SCL pin of the sensor to the bus respectively. It needs another pull-up resistor (4.7k) for ALERT pin, due to open drain structure. For AD0 pin, it is ok to connect to GND, or  $V_{cc}$  or SDA, or SCL pin directly.

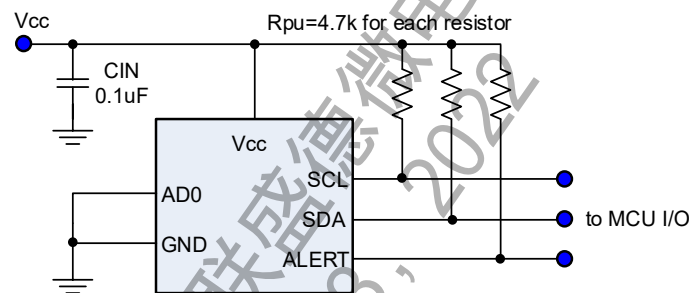

Figure 11. Sensor typical application

### 2.2 PCB Layout

Cautions below are important to improve temperature and humidity measurement accuracy in PCB layout design.

#### 2.2.1 Device Placement

The sensor has to be placed on the top side of the PCB. It is recommended to isolate the sensor from the rest components of the PCB by eliminating copper layers below the device (GND,  $V_{DD}$ ) and creating a slot into the PCB around the sensor to enhance thermal isolation. It is recommended to place the sensor away from any thermal source (e.g. power device in board), high speed digital bus (e.g. memory bus), coil device (e.g. inductors or transformers) and wireless antenna (e.g. Bluetooth, WiFi or RF). It is also recommended to place the sensor to be perpendicular to the ground to prevent dust drop into the cavity. Another important thing is to keep the sensor at good air circulation in the environment to be measured.



Figure 12. sensor placement example at PCB

### 2.2.2 Cin, Pull-up Resistor

It is better to place  $C_{in}$  as close as possible to  $V_{cc}$  and GND pins of the chip. The recommended  $C_{in}$  value is 0.1 $\mu$ F with low ESR ceramic cap although using multi caps, such as 1.0 $\mu$ F plus 0.1 $\mu$ F or 0.01 $\mu$ F, is ok, which can suppress digital noise with different frequency range. User has to put a pull-up resistor with 4.7k to 10k for SDA, SCL and ALERT pins respectively. For AD0 pin, it can be connected to GND,  $V_{cc}$ , SDA or SCL pin directly to assign different slave address, see above table.

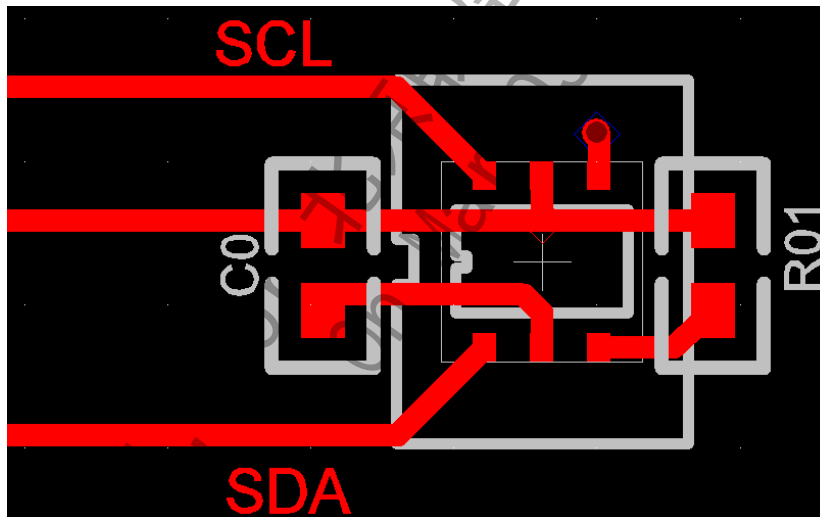

Figure 13. Sensor PCB layout example

### 2.3 Humidity Hysteresis

The measured humidity data of the sensor when environment changes from low to high, like from 10% to 80% could be slightly different from that when environment changes from 80% to 10%, which is called humidity sensor hysteresis. The root cause is the difference of moisture absorption and moisture desorption of sensor transducer material. Figures below show the hysteresis.

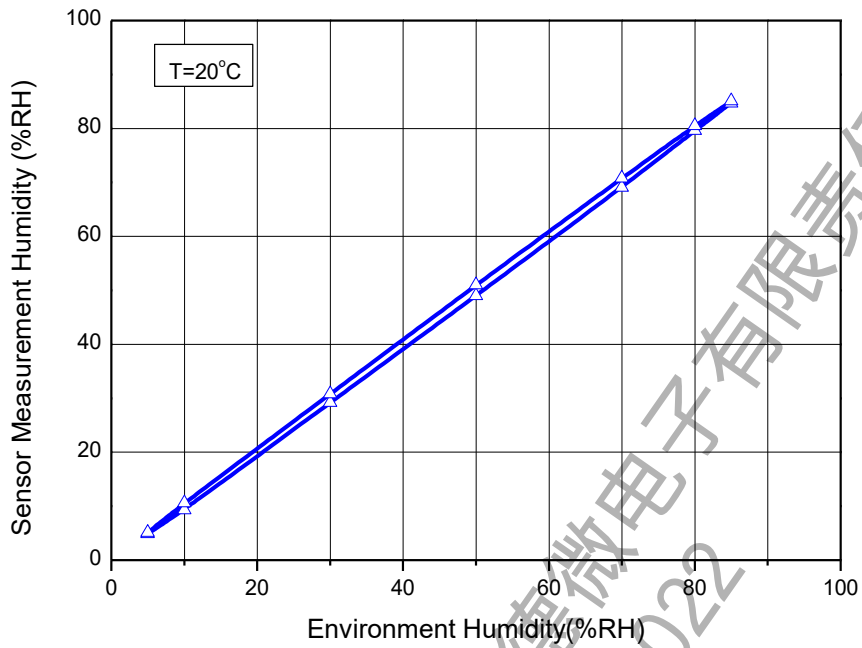

Figure 14. Humidity sensor data vs. environment humidity

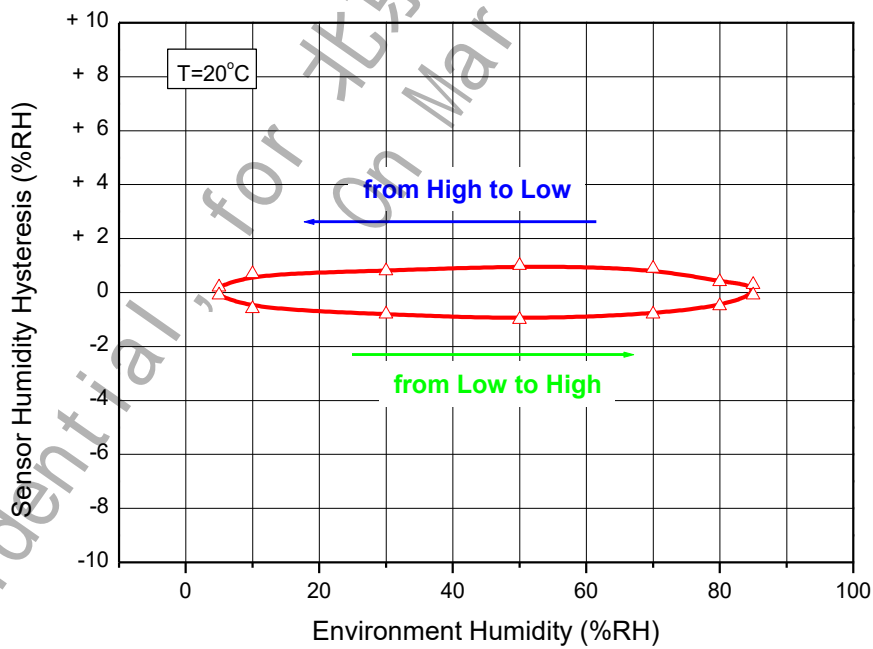

Figure 15. Sensor Humidity Hysteresis vs. environment humidity

## 2.4 Important Notices

It is important to avoid the probability of contaminants coming into contact with the sensor through the open cavity. Dust and other particles as well as liquids could affect the humidity reading data. Also it is recommended to be far away from VOC, which could cause data drift of humidity reading. However the sensor could recover after a few minutes once it is moved to a normal environment. **DO NOT touch the surface of sensor area by inserting hard solid needle into cavity, like tweezers, which could permanently damage the sensor.**

### 2.4.1 Soldering

The CHT8305C chips shipped from the factory is vacuum-packed with to avoid humidity accuracy offset during storage and to prevent moisture issues during solder reflow. The following procedure is recommended during PCB assembly: This sensor chip is compatible with standard board reflow assembly process. It is recommended to use 'No Clean' solder reflow process to reduce water or solvent rinsing impact. If cleaning is needed after reflow, it is recommended to order the chip with cavity protection cover. See ordering information for details. The humidity data of the sensor could be lower if reading immediately after reflow. However it will recover to normal after a few days hydration in normal environment. Do not exceed 300°C over 10s during reflow or manual handling, which could damage the sensor permanently. For details about baking conditions, please contact Sensylink sales.

### 2.4.2 Cavity Protection Cover

The cavity protection cover for CHT8305C is available for order with postfix-'C'. The protection cover sticks to the chip surface and covers the cavity totally. It is NOT necessary to remove this cover after reflow process. It is very effective to block dust and liquid down to 0.40 microns in size.

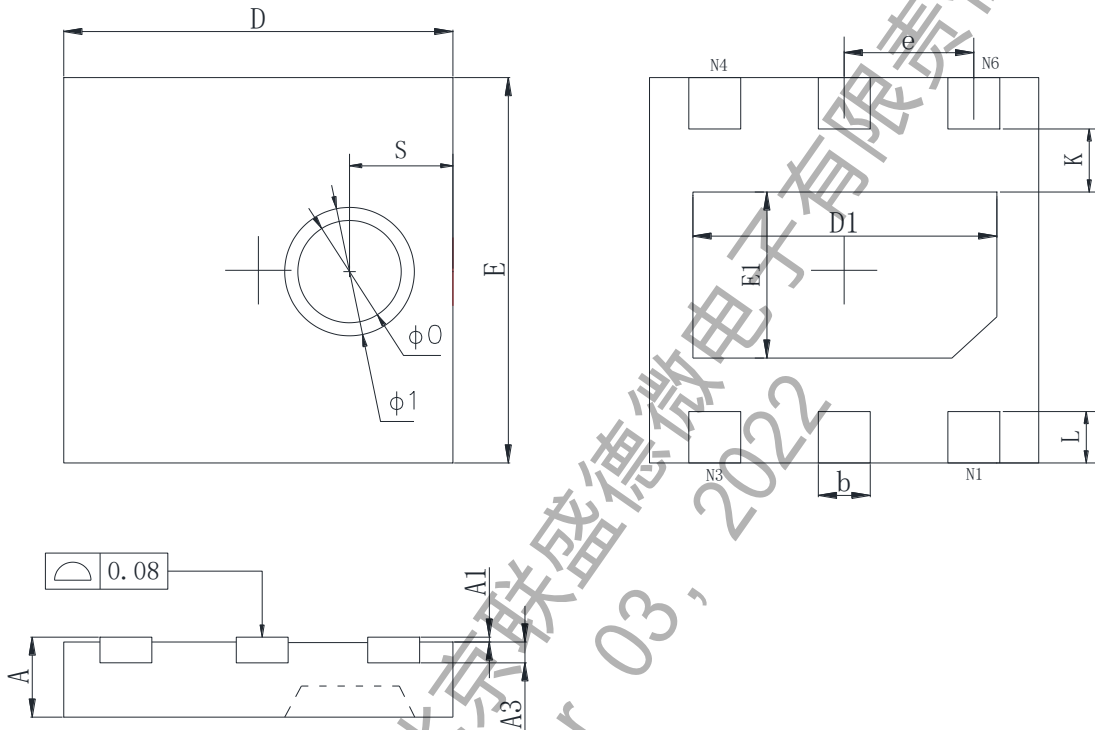
**Package Outline Dimensions (DFN3x3-6)**
**DFN3x3-6 Unit (mm)**

Symbol	Dimensions in Millimeters		Dimensions in Inches	
	Min.	Max.	Min.	Max.
A	0.900	1.100	0.035	0.043
A1	0.010	0.050	0.000	0.002
A3	0.203REF.		0.008REF	
D	2.900	3.100	0.114	0.122
E	2.900	3.100	0.114	0.122
D1	2.300	2.500	0.091	0.098
E1	1.400	1.600	0.055	0.063
k	0.350MIN.		0.014MIN	
b	0.350	0.450	0.014	0.018
e	1.000TYP.		0.040TYP	
L	0.350	0.450	0.014	0.018
S	0.740	0.840	0.029	0.033
φ0	0.800TYP		0.036TYP	
φ1	1.000TYP		0.040TYP	

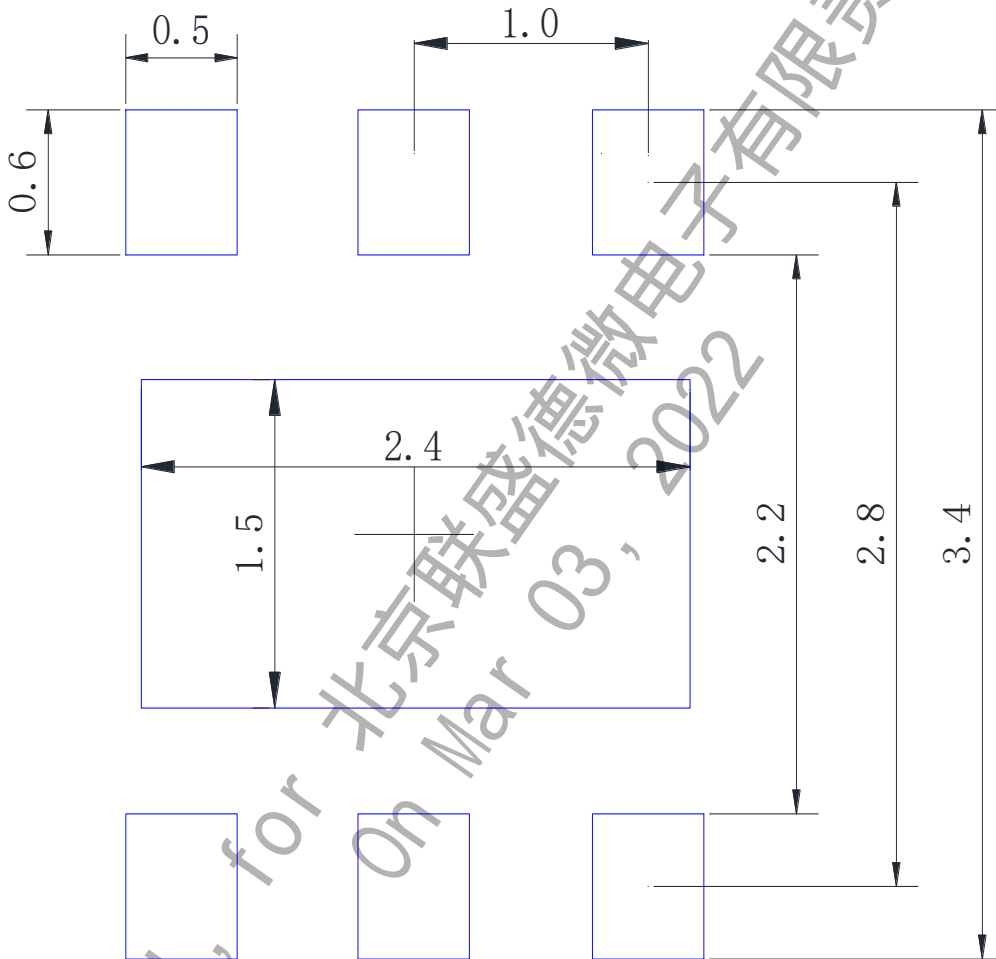

**Recommend Land Pattern Layout (DFN3x3-6)**
**DFN3x3-6**
**Unit (mm)**

**Note:**

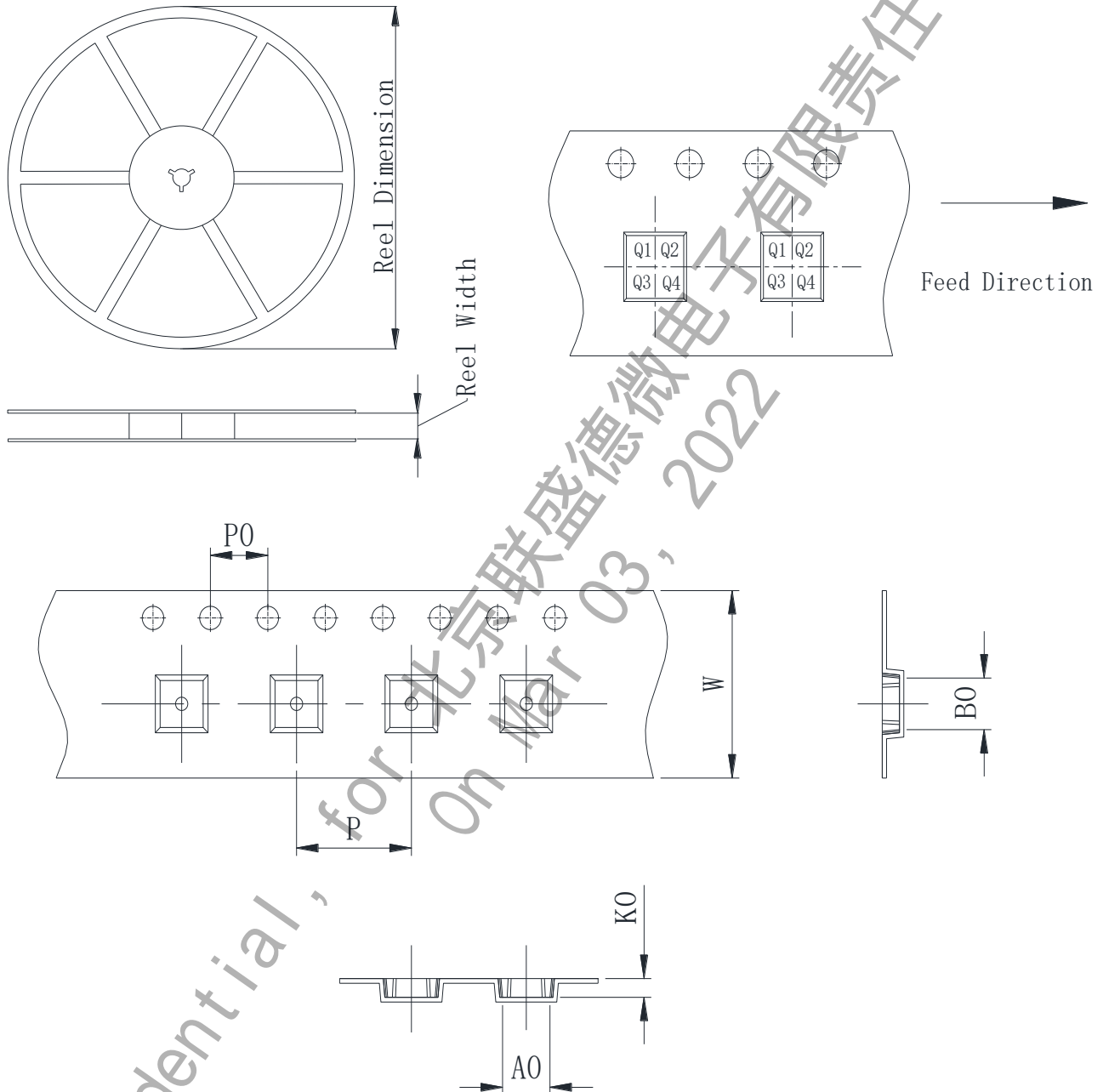
1. All dimensions are in millimeter
2. Recommend tolerance is within  $\pm 0.1\text{mm}$
3. If the thermal pad is not necessary, designer can leave the land pattern area blank
4. Change without notice

**Packing information**

Package type	Reel size	Reel dimension (±3.0mm)	Reel width (±1.0mm)	A0 (±0.1mm)	B0 (±0.1mm)	K0 (±0.1mm)	P (±0.1mm)	P0 (±0.1mm)	W (±0.3mm)	Pin1
DFN3x3-6	13'	330	12.8	3.5	3.5	1.2	8.0	4.0	12.0	Q4

## Revision History

Version	Date	Change Content
Ver2.0	2020-3	Initial Version
Ver2.1	2020-6	Add Packing Information
Ver2.2	2020-7	Change Pin1 orientation in tape& reel
Ver2.3	2020-8	Optimize the read method of temperature and humidity
Ver2.4	2021-8	Update Register Maps Definition(0xFF)
Ver2.5	2021-10	Update Tabel4 status registers definition



## ***SENSYLINK Microelectronics Co., Ltd***

[www.sensylink.com](http://www.sensylink.com)

### **IMPORTANT NOTICE**

SENSYLINK Microelectronics Co., Ltd reserves the right to make modifications, enhancements, improvements, corrections or other changes without further notice to this document and any product described herein or to discontinue any product or service. Customers should obtain the latest relevant information before placing orders and should verify the latest and complete information. SENSYLINK Microelectronics does not assume any responsibility for use of any product, nor does SENSYLINK Microelectronics any liability arising out of the application or use of this document or any product or circuit described herein. SENSYLINK Microelectronics assumes no liability for applications assistance or the design of Customers' products. Customers are responsible for their products and applications using SENSYLINK Microelectronics components. SENSYLINK Microelectronics does not convey any license under its patent or trademark rights nor the other rights.

SENSYLINK Microelectronics Co., Ltd © 2015 - 2021.